

50
250
IX
XO
X

AXOMATIC[®]
GROUP

and PAN TECNICA DIVISION
Tube Filling, Cartoning And Process Solutions



AXOMATIC Filling and Process Solutions leader da sempre nel settore mescolatori sottovuoto, intubettatrici e macchine di processo. Presente sui più competitivi mercati mondiali.

Premiata dal costante successo dei propri prodotti, dotati delle più avanzate tecnologie quali anticipatori di domande sempre più sensibili ai contenuti dell'innovazione.

Il servizio post vendita qualifica anche sotto il profilo commerciale l'eccellenza della società Axomatic verso il cliente.

Axomatic has always been a leader in the filling and process solution sector, and is present in the most competitive and important world markets.

The company is proud of the constant success of its product, which are equipped with the most advanced technology and anticipate increasingly more detailed requests concerning innovation.

Even under the sales profile, the post-sale service is proof of the excellent service that Axomatic gives its clients.

AXOMATIC Filling and Process Solutions war schon immer eines der führenden Unternehmen im Bereich der Tubenfüll - und - verschleißmaschinen sowie der Misch - und Homogenisieretechnik. Die Produkte von AXOMATIC sind auf allen wichtigsten Weltmärkten vertreten und durch ihr attraktives Preis - / Leistungsverhältnis überaus konkurrenzfähig.

AXOMATIC ist durch die konstante Qualität und Zuverlässigkeit seiner Produkte geprägt, die stets über modernste Technologien verfügen und bei denen auf Innovation größten Wert gelegt wird. So ist man bei AXOMATIC auch stets bereit, auf Sonderwünsche des Kunden einzugehen.

Ein weiterer wesentlicher Punkt, den man bei AXOMATIC nie außer acht gelassen hat, ist der Kundenservice, der durch ein weltweites Netz von Vertretungen und Service-Technikern gewährleistet wird.



- ① Volantino di ribaltamento recipiente
 - ② Valvole di ingresso sul coperchio liquidi/polveri
 - ③ Tramoggina per essenze
 - ④ Indicatore allarmi macchina
 - ⑤ Pannello di comando con Touch Screen a colori
 - ⑥ Valvola di scarico
 - ⑦ Specola e lampada per ispezione recipiente
 - ⑧ Sollevamento motorizzato coperchio macchina
- Diversi optional sono disponibili, quali:
- valvola di fondo a tre vie
 - sistema CIP
 - stampa dati
 - riscaldamento a vapore
 - esecuzioni speciali



- ① Manual handwheel for vessel tilting
 - ② Inlet valves on the liquids/powders lid
 - ③ Small hopper for additive, perfumes etc.
 - ④ Light for machine alarm
 - ⑤ Control panel with colour Touch Screen
 - ⑥ Discharge valve
 - ⑦ Observation window with windscreen and lamp
 - ⑧ Machine lid motorized lifting
- Several optional features available, as:
- Three-ways bottom valve
 - CIP system (Cleaning In Place)
 - Data printing
 - Steam heating
 - Special programs



- ① Volante vuelco cuba
 - ② Válvulas de entrada sobre la tapa para líquidos/polvos
 - ③ Tolva pequeña para esencias
 - ④ Indicador alarmas máquinas
 - ⑤ Panel de mando con pantalla táctil de colores
 - ⑥ Válvula de descarga
 - ⑦ Mirilla y lámpara inspección cuba
 - ⑧ Subida motorizada de la tapa de la máquina
- Varios accesorios opcionales disponibles, como:
- Válvula de fondo a tres vías
 - Sistema CIP (Cleaning in Place)
 - Impresión datos
 - Calentamiento con vapor
 - Ejecuciones especiales





- ① Handrad zum Kippen des Kessels
 - ② Einlassventil auf dem Deckel vorgesehen zum Einlass für Flüssigkeiten und Pulver
 - ③ Kleiner Vorlagebehälter für Additive, Parfumes etc.
 - ④ Warnlicht fuer Maschinenstoerung
 - ⑤ Funktionstastatur mit beruehrungsaktivem Farbbildschirm
 - ⑥ Kessel
 - ⑦ Sichtfenster mit Beleuchtung
 - ⑧ Automatisches anheben des Kesseldeckels
- Optionen auf Anfrage:
- 3-Wege-Ventil am Kesselboden
 - CIP-Reinigung (Clean-In-Place)
 - Datenausdruck
 - Aufheizen mit Wasserdampf
 - Sonderprogramme

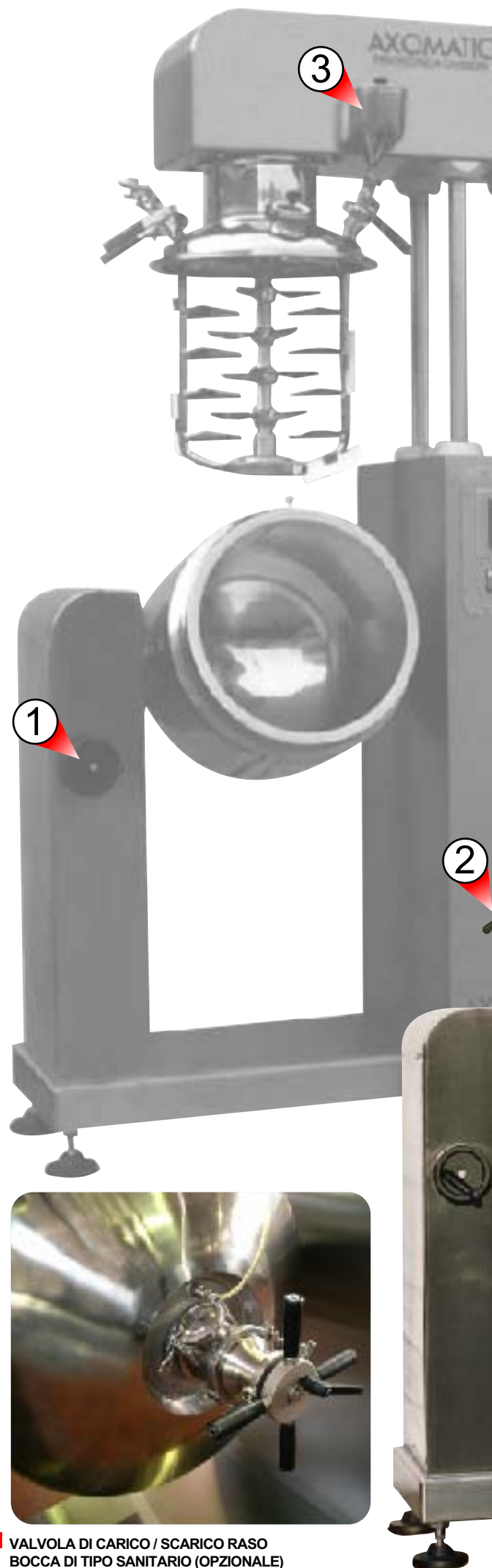

- ① Volant de renversement du récipient
 - ② Vanne d'entrée produit
 - ③ Petite trémie pour charger les essences
 - ④ Indicateur des alarmes de la machine
 - ⑤ Panneau de commandes à couleurs avec touches sensibles
 - ⑥ Vanne papillon pour l'évacuation des produits
 - ⑦ Hublot pour le control visuel
 - ⑧ Levage motorisé du couvercle du récipient
- Différentes options sont disponibles telles que:
- Vanne de fond de cuve à 3 voies
 - Système CIP (Nettoyage en place)
 - Impression des données de production
 - Chauffage par la vapeur
 - Exécutions spéciales



 VALVOLA DI CARICO / SCARICO RASO
BOCCA DI TIPO SANITARIO (OPZIONALE)

 SANITARY CHARGE / DISCHARGE
CENTRAL VALVE (OPTIONAL)

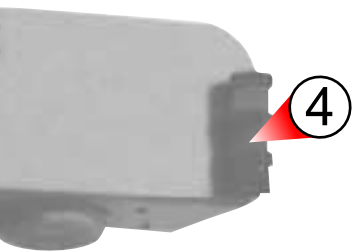



 FUSORI DA 5 Lt. A 2000 Lt.
 PRE-MELTERS FROM 5 UP TO 2000 Lt.



AXOMIC
25
50



 PALE CONTRO-ROTANTI
 CONTRA-ROTATING BLADES

"C" CHIUSO (COVER CLOSE)

"D" SOLLEVATO (COVER OPEN)

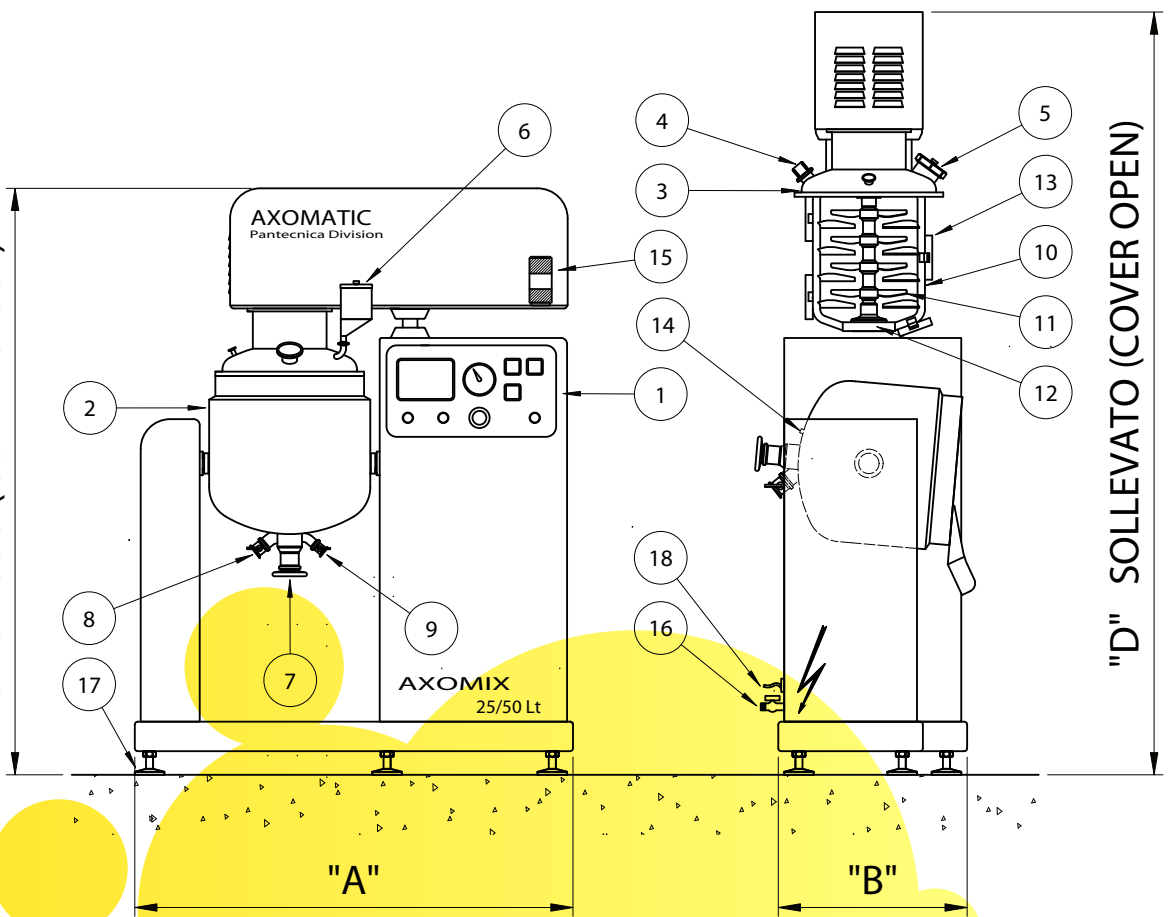

- 18 CONNESSIONE ELETTRICA
- 17 PIEDI REGOLABILI
- 16 RUBINETTO PER CONNESSIONE IDRAULICA
- 15 INDICATORE ALLARMI MACCHINA
- 14 SONDA TEMPERATURA PRODOTTO
- 13 RASCHIANTI
- 12 TURBINA
- 11 PALE MESCOLAZIONE VELOCE
- 10 PALE MESCOLAZIONE LENTA
- 9 CARICO/SCARICO ESSENZE LIQUIDI VALVOLA DI FONDO
- 8 CARICO/SCARICO PRODOTTO VALVOLA DI FONDO
- 7 VALVOLA DI FONDO
- 6 TRAMOGGINA ESSENZE
- 5 SPECOLA PER ISPEZIONE RECIPIENTE CON TERGICRISTALLO
- 4 LAMPADA PER ILLUMINAZIONE INTERNA RECIPIENTE
- 3 COPERCHIO
- 2 RECIPIENTE PRODOTTO
- 1 PANNELLO DI COMANDO

- 18 ELECTRIC CONNECTION
- 17 FOOT SILENT BLOCK
- 16 WATER CONNECTION
- 15 LIGHT FOR MACHINE ALARM
- 14 PROBE PRODUCT TEMPERATURE CONTROL
- 13 SCAPERS (PTFE MADE)
- 12 TURBINE FOR FAST AGITATOR
- 11 CONTRA-ROTATING BLADE AGITATORS
- 10 CONTRA ROTATING BLADE AGITATORS
- 9 INLET/OUTLET RAW MATERIAL VALVE
- 8 INLET/OUTLET PRODUCT VALVE
- 7 CENTRAL BOTTOM VALVE
- 6 VALVE DISCHARGE PLUG VALVE
- 5 OBSERVATION WINDOW WITH WINDSCREEN
- 4 LIGHT FOR INTERNAL ILLUMINATION
- 3 COVER
- 2 VESSEL
- 1 CONTROL PANEL

LITRI - LITRES

	25	50
MOTORE MESCOLAZIONE MOTOR FOR SLOW MIXING	1.5 Kw	1.5 Kw
MOTORE TURBINA MOTORS FOR TURBINE	3 Kw	3 Kw
POMPA DEL VUOTO VACUM PUMP	0.75 Kw	0.75 Kw
RESISTENZE RISCALDAMENTO HEATING ELEMENT	6 Kw	6 Kw

	"A"	"B"	"C"	"D"	Peso
AXOMIX 25 Lt	1485	650	1990	2470	Kg 250
AXOMIX 50 Lt	1485	650	1990	2570	Kg 350

AXOMATIC[®] GROUP

and PAN TECNICA DIVISION
Tube Filling, Cartoning And Process Solutions



STAB. E UFFICI: VIA EINSTEIN, 8 - I-20019 SETTIMO MILANESE (MI) - ITALY
TEL. +39-02-328.53.70 - FAX +39-02-335.02.894
E-mail: sales@axomatic.com - Web site: www.axomatic.com

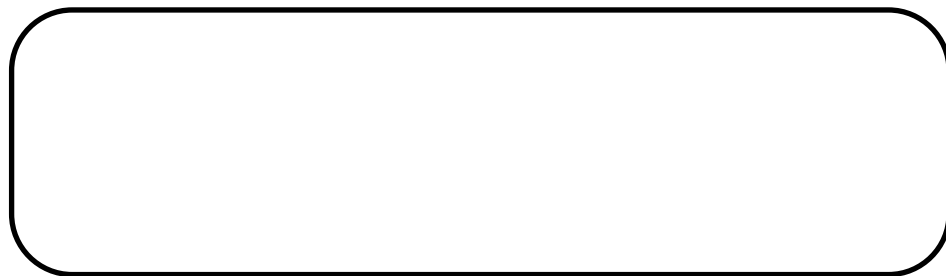

Diritti riservati a termine di legge - Riproduzione anche parziale vietata - AXOMATIC[®]
si riserva di apportare qualsiasi modifica ritenuta migliorativa senza alcun preavviso